

399- Calpet à boule en fonte / Cast iron ball check valve

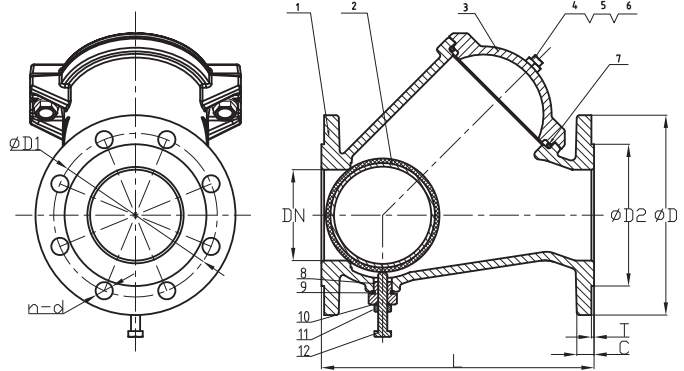

- Face to face acc. to DIN 3202-F6 (EN 558-1 series 48)
- Connection Ends: Flange to EN 1092-2
- Working Pressure: PN10/16
- Temperature Range: 0°C- 80 °C
- Coating: Fusion Bonded Epoxy Coating in accordance with ANSI/AWWA C550
- CE marking

MATERIAL SPECIFICATION

Part No.	Part	Standard Specification
1	Body	EN-GJS-450-10 or EN-GJL-250
2	Ball	Aluminum ball or Steel + EPDM or NBR
3	Cover	EN-GJS-450-10 or EN-GJL-250
4	Bolt	Carbon steel Zinc plated
5	Nut	Carbon steel Zinc plated
6	Flat Washer	Carbon steel Zinc plated
7	O Rings	NBR
8	Nut	Brass or zinc plated steel
9	Washer	EPDM
10	O Rings	NBR
11	Nut	Zinc plated steel
12	Screw	Brass or zinc plated steel

DN		PN	Dimensions(mm)						
Inch	mm		L	D	D1	D2	C	T	n-Ø d
2"	50	10/16	200	165	125	99	19	3	4-Ø 19
2.5"	65	10/16	240	185	145	118	19	3	4-Ø 19
3"	80	10/16	260	200	160	132	19	3	8-Ø 19
4"	100	10/16	300	220	180	156	19	3	8-Ø 19
5"	125	10/16	350	250	210	184	19	3	8-Ø 19
6"	150	10/16	400	285	240	211	19	3	8-Ø 23
8"	200	10	500	340	295	266	20	3	8-Ø 23
		16							12-Ø 23
10"	250	10	600	405	350	319	22	3	12-Ø 23
		16			355				12-Ø 28
12"	300	10	700	460	400	370	24.5	4	12-Ø 23
		16			410				12-Ø 28
16"	400	10	900		515				16-Ø 28
		16			525				16-Ø 31